

DIMENSIONI D'INGOMBRO - OVERALL DIMENSIONS

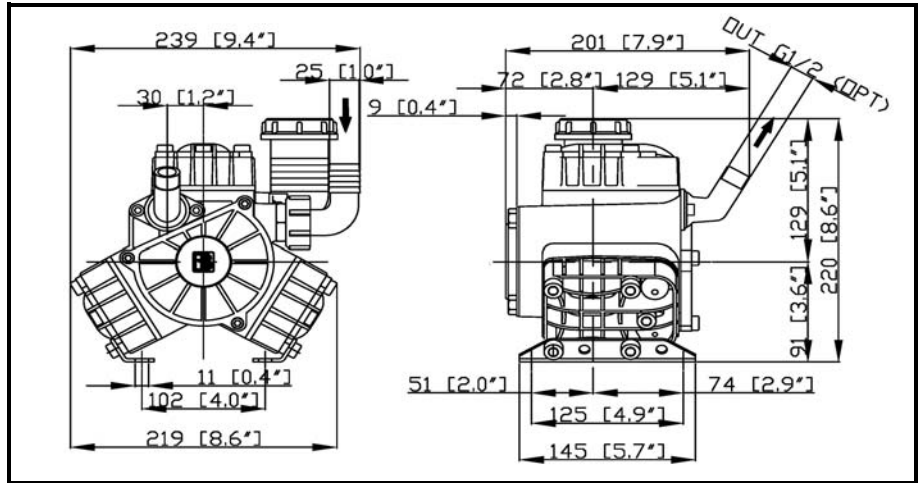

ALBERO POMPA - PUMP SHAFT

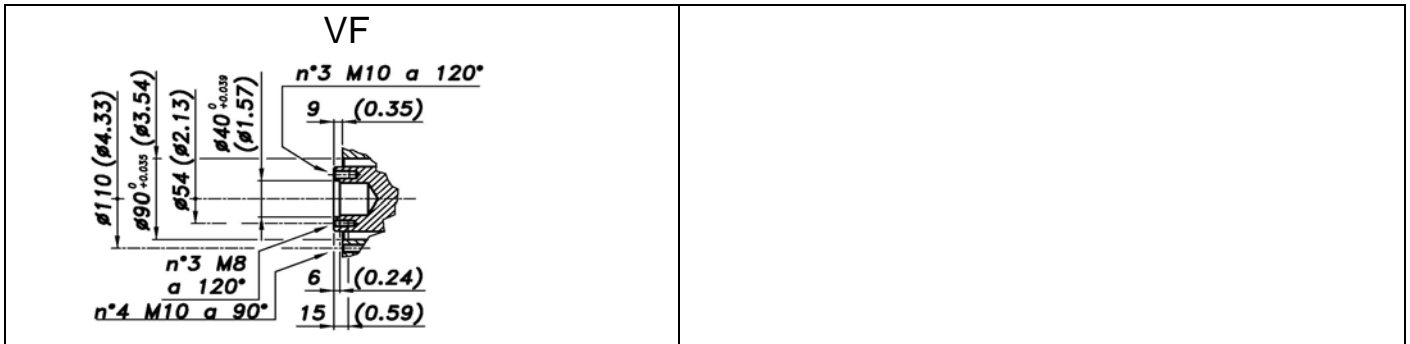

COPPIA DI SERRAGGIO - TORQUE CHART

CODICE - CODE	Q.TY	POS	N-m	Lbr.ft
86.2131.00.2	3	9	10	7,4
86.2730.00.2	2	20	10	7,4
86.2168.00.2	2	7	10	7,4
86.2893.00.2	11	43	22	16,2
86.2900.00.2	4	13	22	16,2
86.3185.00.2	4	36	22	16,2
03.0021.97.3	3	44	5	3,7
Tolleranza di serraggio: 0/-10%				
Tolerance on torque value: 0/-10%				

INFORMAZIONI UTILI
USEFUL INFORMATION

LUBRIFICANTE- LUBRICANT:				
OLIO MOTORE O SEMIDRAULICO SAE 30 MOTOR OIL OR SEMI-HYDRAULIC OIL SAE 30				
PRESSIONE ACCUMULATORE ACCUMULATOR PRESSURE				
PRESSIONE DI LAVORO - OPERATING PRESSURE	2 ÷ 5	5÷10	10 ÷ 20	20 ÷ 50
ACCUMULATORE ACCUMULATOR	/	/	/	/

KIT MEMBRANE - DIAPHRAGMS KIT

KIT	03.9876.97.3		03.9877.97.3		03.9872.97.3									
POSIZIONE ESPLOSO POSITION NUMBER	BUNA - N		DESMOPAN		PENTAX									
	1	4	1	4	1	4								
QUANTITA' NEL KIT QUANTITIES INCLUDED	3	6	3	6	3	6								

KIT POMPA/KIT VALVOLE - PUMP KIT/VALVES KIT

KIT	03.9874.97.3				03.9875.97.3											
POSIZIONE ESPLOSO POSITION NUMBER	KIT POMPA VM PUMP KIT VM				KIT VALVOLE VALVE KIT											
	4	38	10	11	2	4										
QUANTITA' NEL KIT QUANTITIES INCLUDED	1	1	1	6	6	6										

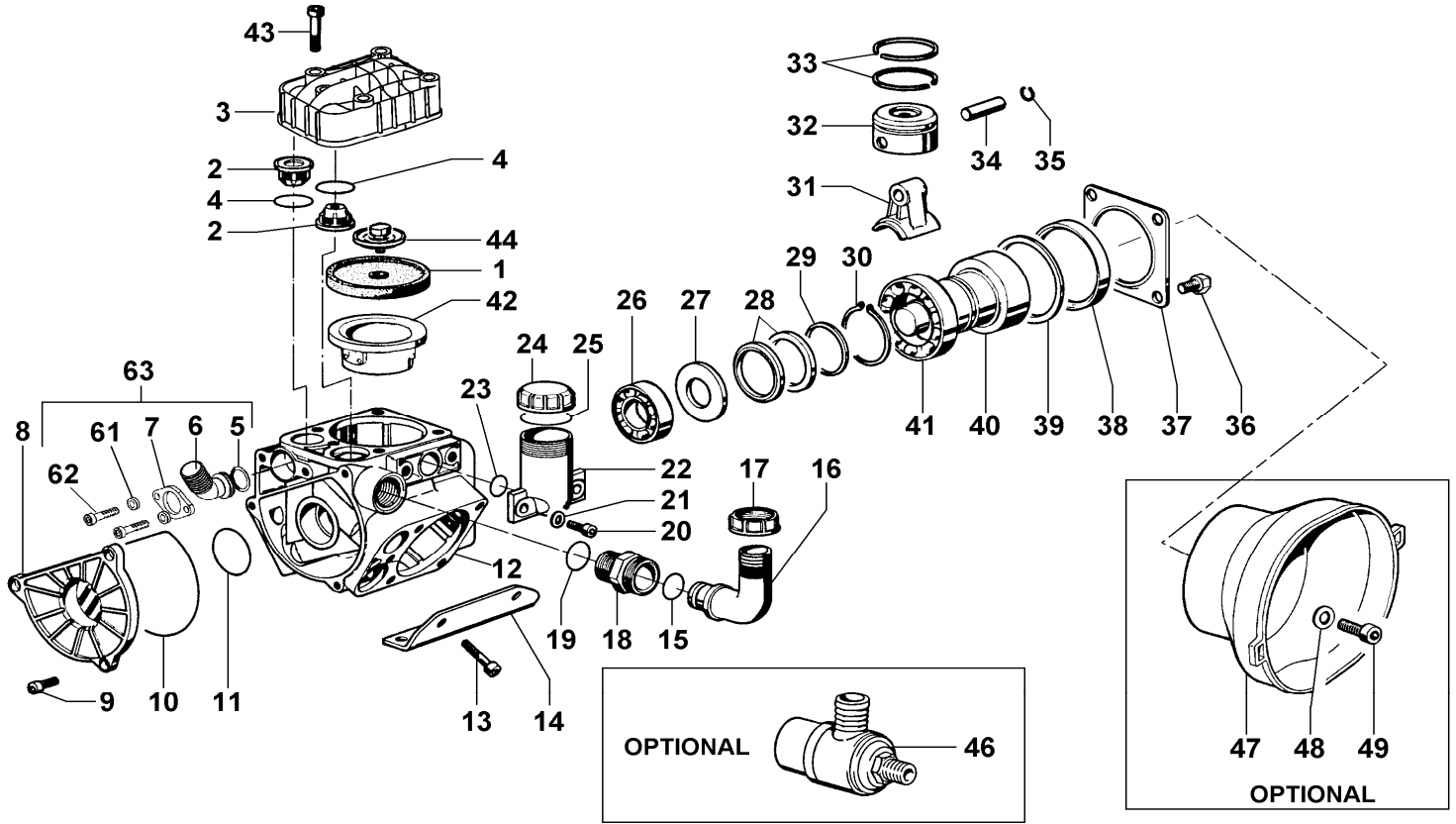

POS.	CODICE PART NO. REF.	DENOMINAZIONE - DESCRIPTION - DESCRIPTION	Q.TY
1	03.0040.31.2	PISTON DIAPHRAGM	3
1	03.0040.00.2	DESMOPAN PISTON DIAPHRAGM	3
1	03.0040.36.2	HPS PISTON DIAPHRAGM	3
2	03.9821.97.3	VALVE ASSY	6
3	03.0202.09.2	HEAD	3
4	03.0029.36.2	VALVE SEAL	6
5	80.3218.00.2	O-RING 3,0x22	1
6	31.1515.09.2	OUTLET FLANGE G.1/2	1
7	31.1517.61.2	FLANGE	1
8	03.0003.09.2	SUCTION COVER	1
9	86.2131.00.2	SCREW M6x18 UNI5931	3
10	80.3210.66.2	O-RING 2,62x101,27	1
11	80.3208.30.2	O-RING 2,62x36,14	1
12	03.0001.09.2	CRANKCASE	1
13	86.2900.00.2	SCREW M8x55 UNI5931	4
14	03.0014.61.2	MOUNTING RAIL	2
15	80.3200.00.2	O-RING 2,62x22,22	1
16	84.0542.00.2	90° ELBOW CONNECTOR DIA.25-1"	1
17	82.0049.00.2	WING NUT M34	1
18	83.5062.10.2	NIPPLES G.3/4-M34	1
19	80.3205.00.2	O-RING 2,62x25,07	1
20	86.2730.00.2	SCREW M8x30 UNI5931	2
21	84.3685.00.2	WASHER DIA.8,4x15x1,5	2
22	23.0008.32.2	OIL FILLER	1
23	80.3180.00.2	O-RING 2,62x15,08	1
24	85.2750.00.2	OIL FILLER CAP	1
25	82.4120.00.2	GASKET DIA.45x19x1,5	1

POS.	CODICE PART NO. REF.	DENOMINAZIONE - DESCRIPTION - DESCRIPTION	Q.TY
26	81.2646.00.2	BEARING DIA.20x52x15	1
27	03.0011.61.2	SPACER	1
28	94.0047.76.2	CONROD RING	2
29	03.0012.61.2	SPACER	1
30	80.1331.00.2	SHAFT RING D.45	1
31	03.0005.09.2	CONROD	3
32	03.0006.09.2	PISTON DIA.48	3
33	81.8502.50.2	PISTON RING	6
34	85.2006.00.2	PISTON PIN DIA.10	3
35	80.0003.00.2	RING DIA.10	6
36	86.3185.00.2	SCREW M10x16 UNI5739	4
37	17.0013.61.2	COVER	1
38	80.2264.10.2	OIL SEAL DIA.68x90x10	1
39	03.0015.61.2	SPACER	1
40	03.0017.26.2	CRANKSHAFT	1
41	81.2933.00.2	BEARING DIA.45x75x16	1
42	03.0007.01.2	PISTON SLEEVE	3
43	86.2893.00.2	SCREW M8x50 UNI5931	1
44	03.0021.97.3	KIT DIAPHRAGM WASHER/SCREW AISI 316	3
46	24.3040.97.3	SAFETY VALVE 40bar (OPTIONAL)	1
47	31.1482.32.2	PLAIN SAFETY CONE (OPTIONAL)	1
48	84.3810.00.2	WASHER DIA.10,5x21x2	4
49	86.3212.00.2	SCREW M10x20 UNI5931	4
61	84.3585.00.2	WASHER D.6 UNI6592	2
62	86.2108.00.2	SCREW M6x16 UNI5931	2
63	31.8916.97.3	KIT G.1/2"	1